

HOCHLEISTUNGS-GELENKKÖPFE
Mit integrierter Pendelkugel-
lagerung, Maßreihe K, Innen-
gewinde, Anschlussmaße nach
DIN ISO 12240-4 und DIN ISO 8139

HEAVY-DUTY ROD ENDS
 With integral self-aligning ball bearing, series K, female thread, according to ISO 12240-4 and DIN ISO 8139

→ **Sonderanfertigungen auf Anfrage**
 → Custom made products on request

Gehäuse:
 Geschmiedeter Einsatzstahl, vergütet, Laufbahn gehärtet und feinstbearbeitet, Oberfläche galvanisch verzinkt, Cr VI-frei

Innenring:
 Wälzlagerstahl, gehärtet, feinstbearbeitet

Wälzkörper:
 Wälzlagerstahl, gehärtet, feinstbearbeitet

Wartung:
 Wartungsarm, nachschmierbar, befüllt mit Aluminiumkomplexseifenfett, Zulassung nach USDA H1, Temperaturbereich -45 °C bis +120 °C

Schmiernippel:
 Trichterschmiernippel DIN 3405 D1/A (bis Größe 10/ Kegelschmiernippel DIN 71 412 H1 (ab Größe 12), weitere Schmiernippel siehe Seite 063

Toleranzen:
 Seite 050 – 057

Housing:
 Forged steel, case hardened bearing race, superfinished, surface galvanized, free of Cr VI

Inner ring:
 Ball bearing steel, hardened, superfinished

Rolling element:
 Ball bearing steel, hardened, superfinished

Maintenance:
 Low maintenance, lubrication possible, aluminium-complex-soap-grease, approval according to USDA H1, temperature range -45 °C to +120 °C

Grease nipple:
 DIN 3405 D1/A (until size 10) / DIN 71 412 H1 (from size 12), further grease nipples see on page 063

Tolerances:
 Page 050 – 057

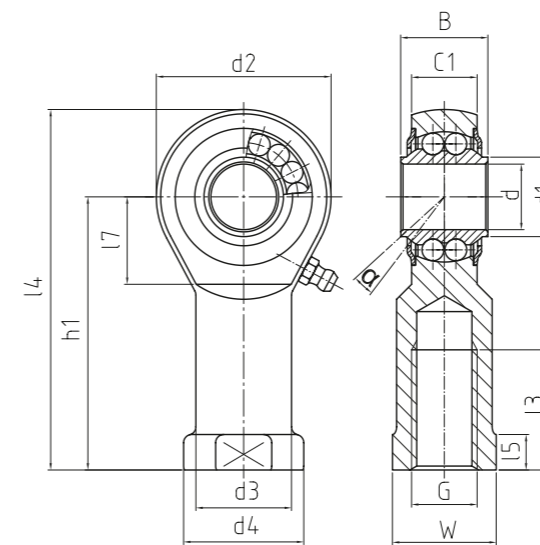

BRF

Hochleistungs-Gelenkköpfe
 Heavy-duty rod ends

PREMIUM Line +

Bestellnummer Order number			Abmessungen Measurements [mm]														Kippwinkel Tilt angle	Gewicht Weight	Drehzahlgrenze Rotational speed limit	Axialfaktoren Axial factor		Tragzahlen Basic load rating		Radiale Lagerluft Radial clearance	
Typ Type	Rechtsgewinde Right hand thread	Linksgewinde Left hand thread	d	G	B	C1	h1	d1	d2	d3	d4	l3	l4	l5	l7	W	α (°)	kg	n ^{max.} (min ⁻¹)	Y	Y0	dyn C (kN)	stat Co (kN)	CN (µm)	d
BRF 06 - 00	-501	-502	6	M 6	9	6,75	30	9	20	10	13	12	40	5	10	11	8	0,024	1.350	2,09	2,19	2,8	0,7	10 – 30	6
BRF 08 - 00	-501	-502	8	M 8	12	9	36	10,4	24	12,5	16	16	48	5	12	14	8,5	0,044	1.300	1,8	1,89	4	1	10 – 30	8
BRF 10 - 00	-501	-502	10	M 10	14	10,5	43	12,7	28	15	19	20	57	6,5	15	17	8	0,072	1.225	1,9	1,81	4,5	1,5	10 – 30	10
BRF 10 - 01	-501	-502	10	M 10 x 1,25	14	10,5	43	12,7	28	15	19	20	57	6,5	15	17	8	0,072	1.225	1,9	1,81	4,5	1,5	10 – 30	10
BRF 12 - 00	-501	-502	12	M 12	16	12	50	14,6	32	17,5	22	22	66	6,5	16	19	7,5	0,107	1.125	1,74	1,82	5	1,8	10 – 30	12
BRF 12 - 01	-501	-502	12	M 12 x 1,25	16	12	50	14,6	32	17,5	22	22	66	6,5	16	19	7,5	0,107	1.125	1,74	1,82	5	1,8	10 – 30	12
BRF 14 - 00	-501	-502	14	M 14	19	13,5	57	17,3	36	20	25	25	75	8	20	22	6	0,16	1.025	2,36	2,48	5,6	2	10 – 30	14
BRF 16 - 00	-501	-502	16	M 16	21	15	64	19	42	22	27	28	85	8	22	22	8	0,224	975	2,24	2,35	6,3	2,4	10 – 30	16
BRF 16 - 01	-501	-502	16	M 16 x 1,5	21	15	64	19	42	22	27	28	85	8	22	22	8	0,224	975	2,24	2,35	6,3	2,4	10 – 30	16
BRF 18 - 00	-501	-502	18	M 18 x 1,5	23	16,5	71	21,9	46	25	31	32	94	10	24	27	8,5	0,293	900	2,21	2,31	7,1	2,9	10 – 30	18
BRF 20 - 00	-501	-502	20	M 20 x 1,5	25	18	77	24,3	50	27,5	34	33	102	10	26	30	7	0,367	825	2,46	2,58	7,9	3,5	10 – 30	20
BRF 22 - 00	-501	-502	22	M 22 x 1,5	28	20	84	25,8	54	30	38	37	111	12	26	32	8	0,48	725	2,35	2,24	9,3	4	10 – 30	22
BRF 25 - 00	-501	-502	25	M 24 x 2	31	22	94	30,1	64	30	35	42	126	10	32	30	5	0,572	600	2,02	2,12	11	5,7	10 – 30	25
BRF 30 - 00	-501	-502	30	M 30 x 2	37	25	110	34,5	70	40	50	51	145	15	35	41	7,5	0,978	450	2,24	2,35	14,2	7,5	10 – 30	30
BRF 35 - 00*	-501	-502	35	M 36 x 3	48	35	137	44,5	90	51	65	70	182	20	48	50	7	2,25	400	1,971	2,065	23,4	11,2	10 – 30	35
BRF 40 - 00*	-501	-502	40	M 42 x 3	66	49	170	60	120	58	70	80	230	22	70	60	7	4,65	360	2,008	2,104	36,7	16,7	10 – 30	40

* Auf Anfrage | on request